

# Division of Laboratory Systems



## PHMSA Training Program Requirements: Shipping Hazmat such as Cat A

Elizabeth A. LaDow

February 27, 2023



# Agenda

- Introduction
  - *New and relevant OneLab™ Resources*
  - *Today's Presenter*
- *PHMSA Training Program Requirements: Shipping Hazmat such as Cat A*
- Q&A
- Upcoming Events



# INTRODUCING OneLab™

→ REACH

A Learning Management System for  
Clinical and Public Health Laboratory Professionals

Give your learners access to the newest  
and most relevant CDC-developed COVID-19  
education and training.



Download free  
materials



Earn Continuing  
Education Units  
(Including P.A.C.E.®)



Access OneLab  
REACH on your  
mobile device

**Register  
Today!**



OneLab REACH™ is part of the CDC OneLab initiative. OneLab's mission is to strengthen interconnections between clinical, public health, and CDC laboratory education and training professionals to collectively support rapid, large-scale responses to public health emergencies.

Learn more at [www.cdc.gov/onelab](http://www.cdc.gov/onelab)



# Presenter



## **Elizabeth A. LaDow**

---

*Community Liason*

Southern Regional Office

Office of Hazardous Materials Safety Administration, Field Operations

Pipeline and Hazardous Materials Safety Administration (PHMSA)

U.S Department of Transportation (DOT)



## Division of Laboratory Systems

- Slide decks may contain presentation material from panelists who are not affiliated with CDC. Presentation content from external panelists may not necessarily reflect CDC's official position on the topic(s) covered.





# PHMSA Training Program Requirements

## Shipping Hazmat such as Cat A



U.S. Department of Transportation  
Pipeline and Hazardous Materials  
Safety Administration

**PHMSA: Your Safety is Our Mission**



# PHMSA Electronic Newsletter



U.S. Department of Transportation  
Pipeline and Hazardous Materials  
Safety Administration

**PHMSA: Your Safety is Our Mission**



# 49 CFR Parts 100-180 Refresher



U.S. Department of Transportation  
Pipeline and Hazardous Materials  
Safety Administration

**PHMSA: Your Safety is Our Mission**





# Learning Aids



## TRANSPORTING INFECTIOUS SUBSTANCES SAFELY



U.S. Department  
of Transportation  
Pipeline and  
Hazardous Materials  
Safety Administration

[WWW.PHMSA.DOT.GOV](http://WWW.PHMSA.DOT.GOV)



U.S. Department of Transportation  
Pipeline and Hazardous Materials  
Safety Administration

**PHMSA: Your Safety is Our Mission**



# Learning Aids



## HAZMAT TRANSPORTATION TRAINING REQUIREMENTS

*An Overview of 49 CFR PARTS 172-173*



U.S. Department  
of Transportation  
Pipeline and  
Hazardous Materials  
Safety Administration

[WWW.PHMSA.DOT.GOV](http://WWW.PHMSA.DOT.GOV)



## GUIDE TO DEVELOPING A HAZMAT TRAINING PROGRAM

*General Awareness, Function-Specific, Safety, Security Awareness, and In-Depth Security Training.*



U.S. Department  
of Transportation  
Pipeline and  
Hazardous Materials  
Safety Administration

[WWW.PHMSA.DOT.GOV](http://WWW.PHMSA.DOT.GOV)



U.S. Department of Transportation  
Pipeline and Hazardous Materials  
Safety Administration

**PHMSA: Your Safety is Our Mission**



# Why is training important?



# Human Error

Human error may result from a variety of factors including:

- Lack of knowledge leading to mishandling of hazmat
- Lack of knowledge leading to undeclared shipments
- Lack of awareness that hazmat is present
- Failure to follow established safety procedures
- Lack of knowledge of how to respond to an incident





# Inspection Trends

- Failure to maintain training records
- Failure to train hazmat employees
- Packages not properly marked and labeled
- Incorrect shipping papers
- Failure to register with PHMSA
- Lack of a Security Plan



# Objectives

- Clarify training requirements in the HMR
- Identify employees who must be trained and to determine what type of training may be best for the employees
- Familiarize the hazmat employers and employees with publications and training materials available from PHMSA



# An Effective Program

- Develops strong safety culture
- Heightens employee safety
- Improves a company's effectiveness, efficiency and productivity
- Increases employee skills
- Aids in ensuring safe and secure shipments
- Reduces likelihood of catastrophic event such as fire aboard aircraft
- Provides employees an understanding of compliance



# 49 CFR Section 171.8

## Definitions





# Hazmat Employer

- Any person who uses one or more employees to:
- Transport hazmat in commerce
  - Cause hazmat to be transported or shipped
  - Represent, mark, certify, sell, offer, recondition, test, repair or modify packagings

**LEARNING AID: 49 CFR, Part 171, Section 171.8**



# Hazmat Employee

A person who is:

- Employed full-time, part time, or temporarily
- Directly affecting hazmat transportation safety
- Loads, unloads or handles hazmat
- A lab tech or the administrative position who handles mailings
- Designs, manufactures, inspects, marks, tests, or reconditions packagings
- Prepares hazmat for transportation
- Operates a transport vehicle



## LEARNING AID: 49 CFR, Part 171, Section 171.8



# 49 CFR, Subpart H, Section 172.702

## Applicability and responsibility for training and testing



# Responsibility for Training

- A *hazmat employer* shall ensure that each of their *hazmat employees* is trained
- The responsibility for training (*and the civil penalties for not training*) rests with the *employer*
- A *hazmat employer* is responsible for maintaining records of the training

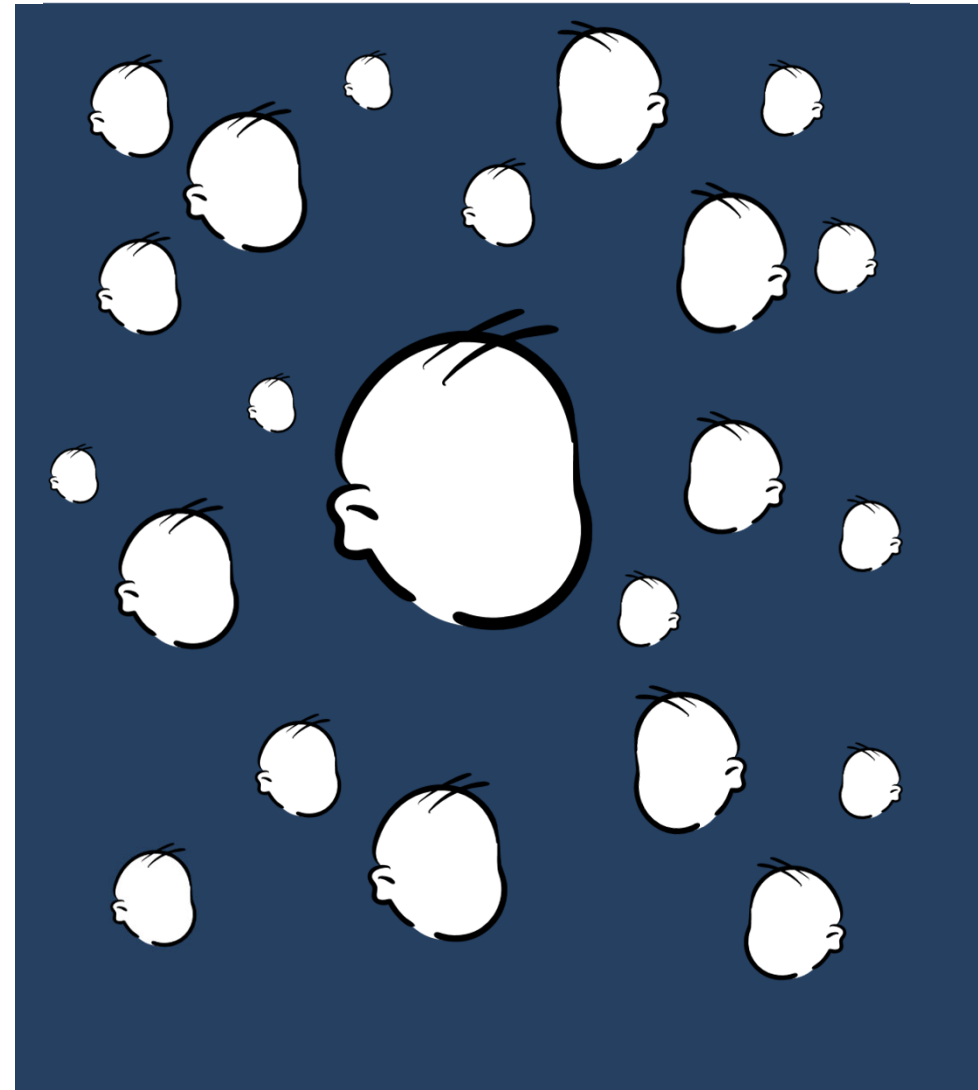

**LEARNING AID: 49 CFR, Part 172, Subpart H, Section 172.702**





# 49 CFR, Subpart H, Section 172.704

## Training requirements





Training is a “systematic program” that includes:

- General awareness and familiarization training
- Function-specific training
- Safety training
- Security awareness training



**LEARNING AID: 49 CFR, Part 172, Subpart H, Section 172.704 (a)**

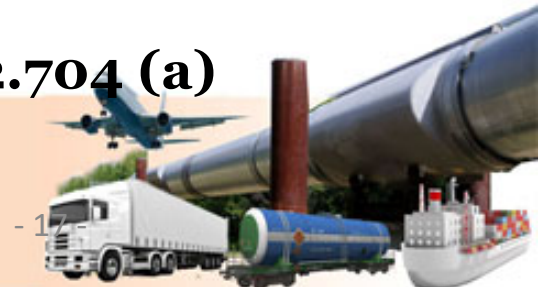

# General Awareness and Familiarization



- Provide familiarity with the requirements of the HMR
- Enable hazmat employees to recognize and identify hazardous materials using the hazard communication

**LEARNING AID: 49 CFR, Part 172, Subpart H, Section 172.704 (a)**

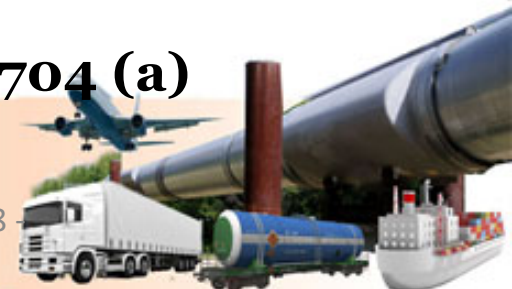

# Function-Specific Training

- A more detailed understanding of the HMR
- Training employees on their job functions related to hazmat transportation
- Usually accomplished through on-the-job training (OJT)

**LEARNING AID: 49 CFR, Part 172, Subpart H, Section 172.704 (a)**

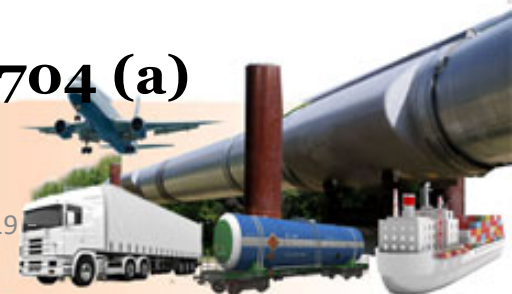



# Function-Specific Training

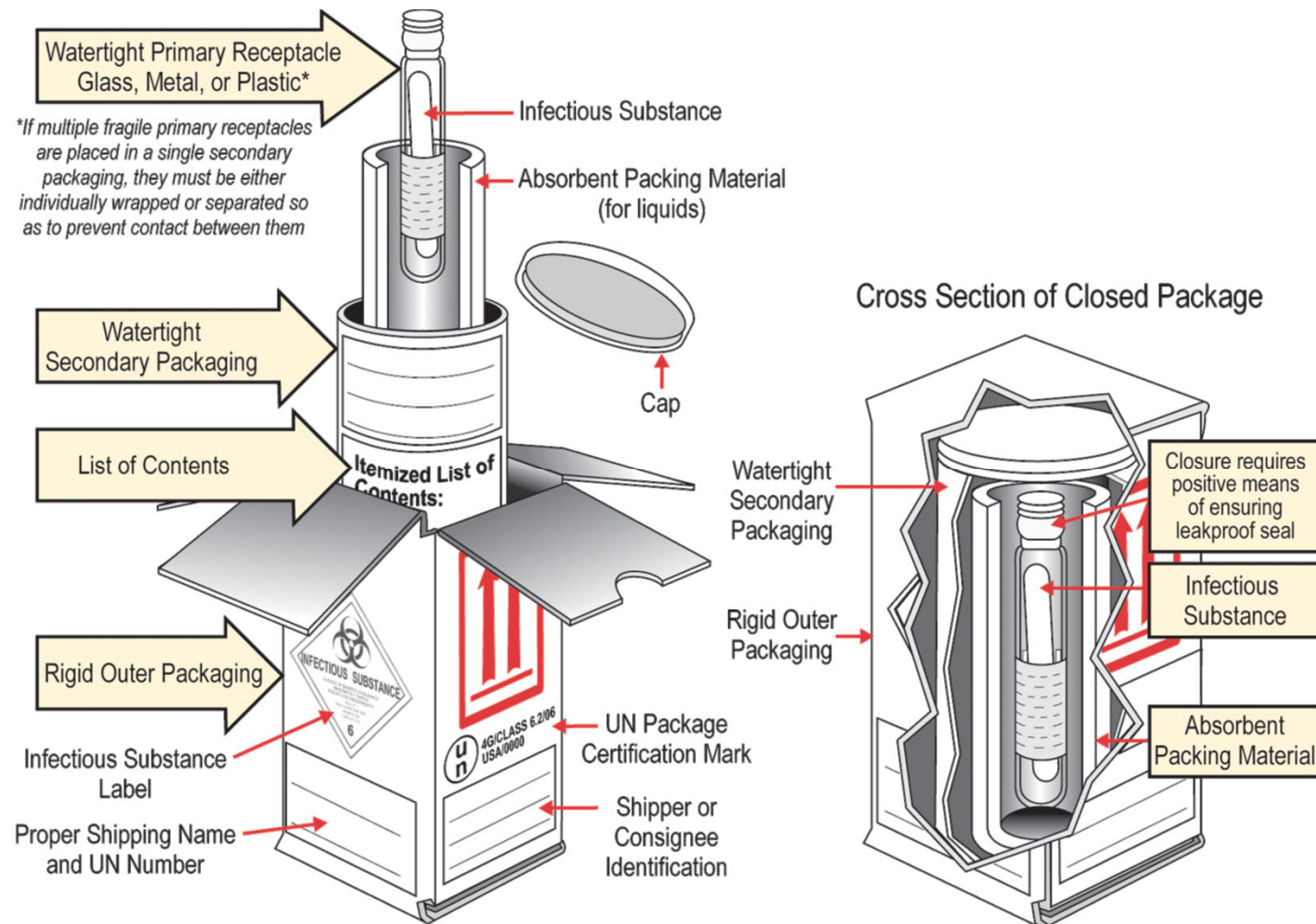

## LEARNING AID: Transporting Infectious Substances Safely



# Function-Specific Training

## Category A Package Marking and Labeling

- Proper shipping name & UN 2814 or UN 2900 (\*No tech name on pkg per 172.301(b))
- Shipper or Consignee identification
- Infectious Substance Label 172.432
- Orientation arrows (as applicable)
- **Category A Technical Name Requirements:** 49 CFR 172.301(b) states in part, “A technical name should not be marked on the outer package of a Division 6.2 material.”



## LEARNING AID: Transporting Infectious Substances Safely



# Function-Specific Training

## Category A Shipping Papers

- UN Identification Number
- Proper Shipping Name
- Tech Name (49 CFR 172.203(k) & 171.8)
  - Generic microbiological group or
  - “Suspected Category A infectious substance”
- Hazard Class/Division
- NO Packing Group
- # and Type of Pkg / Weight (lbs. or kg)
- Shipper’s Certification
- Emergency Response Telephone Number

**LEARNING AID: Transporting Infectious Substances Safely**



# Safety Training

- Hazards presented by hazardous material
- Safe handling
- Emergency response information
- Methods and procedures for accidental release



**LEARNING AID: 49 CFR, Part 172, Subpart H, Section 172.704 (a)**

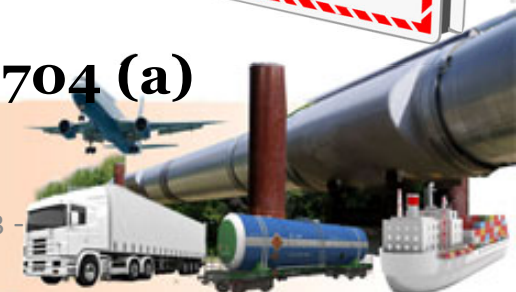



# Security Awareness Training

- Awareness of security risks associated with hazmat transportation
- Methods to enhance transportation security
- How to recognize and respond to possible security threats
  - Potential Threats
  - Potential Targets
  - Prevention Tools

**LEARNING AID: 49 CFR, Part 172, Subpart H, Section 172.704 (a)**

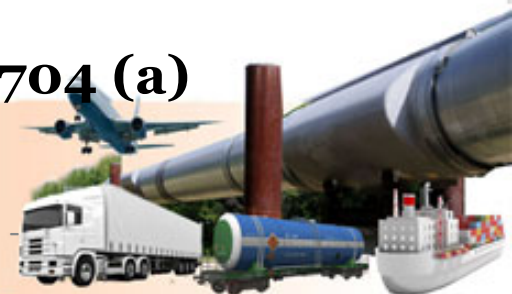

# Testing



- Each hazmat employer must ensure that every hazmat employee is tested.
- The HMR does not specify the type of test or grading. This could be a written test, verbal test or performance test. Remember that this must be properly documented.

**LEARNING AID: 49 CFR, Part 172, Subpart H, Section 172.704 (d)**



# Training Records (1 of 2)

The training record must include:

- Hazmat employee's name
- Most recent training completion date
- Description, copy, or location of the training materials
- Name and address of person providing the training
- “Certification” that the hazmat employee has been trained and tested

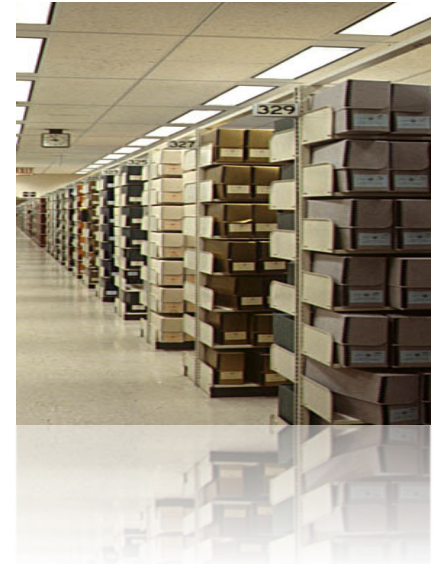

**LEARNING AID: 49 CFR, Part 172, Subpart H, Section 172.704 (d)**

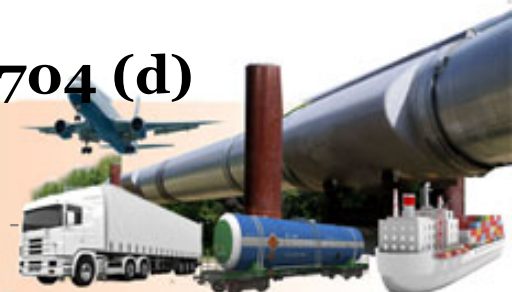

# Training Records (2 of 2)

## HAZMAT EMPLOYEE TRAINING RECORD

### General Awareness / Familiarization Training

Description, Copy, and Location of Training	Trained By	Date Trained	Test / Score
Hazmat Training Introduction Video	Training Officer Janet	July 14, 2017	No Test
Hazmat Transportation Training Modules (On-line)	Training Officer Janet	July 14, 2017	On-line Test; 95%

### Function-Specific Training

Description, Copy, and Location of Training	Trained By	Date Trained	Test / Score
Cylinder Requalification Instruction Book	Supervisor Dan	July 21, 2017	Written Test; 98%
Performance demonstration of Packaging, Marking and Labeling Checklist of tasks performed attached to this training record	Supervisor Dan	July 21, 2017	Live Demonstration Test; 100%

### Safety Training

Description, Copy, and Location of Training	Trained By	Date Trained	Test / Score
Personal Safety Information Book	Supervisor Dan	July 14, 2017	Written Test; 100%

### Security Awareness Training

Description, Copy, and Location of Training	Trained By	Date Trained	Test / Score
Hazmat Transportation Security Awareness Training Module (On-line)	Training Officer Janet	July 28, 2017	On-line Test; 90%

### In-Depth Security Training

Description, Copy, and Location of Training	Trained By	Date Trained	Test / Score
Company Security Plan and Risk Guidelines Binder	Supervisor Dan	July 28, 2017	Verbal Test; Passed

I certify that the hazmat employee identified on this training record has been trained and tested as required by the Hazardous Materials Regulations, 49 CFR Part 172 Subpart H.

## LEARNING AID: Guide to Developing a Hazmat Training Program





# Record Retention

A record shall be:

- Created and retained by hazmat employer
- A current training record must be retained as long as hazmat employee is employed by that employer, and
- Retained for **90 days** after employee is no longer employed by that employer



**LEARNING AID: 49 CFR, Part 172, Subpart H, Section 172.704 (d)**



# Training Frequency

- Initial training must be completed within **90 days** of hazmat employment or change in job function.
- Hazmat employees must be directly supervised by a trained and knowledgeable employee until trained themselves.
- Recurrent (refresher) training is required *at least every three years*.

**LEARNING AID: 49 CFR, Part 172, Subpart H, Section 172.704 (c)**



# How to Begin

- Determine who your hazmat employees are
- Determine the employees needs
- Develop a safety culture
- Designate a training coordinator
- Implement a planning process
- Implement a process for recordkeeping
- Understand the training curriculum

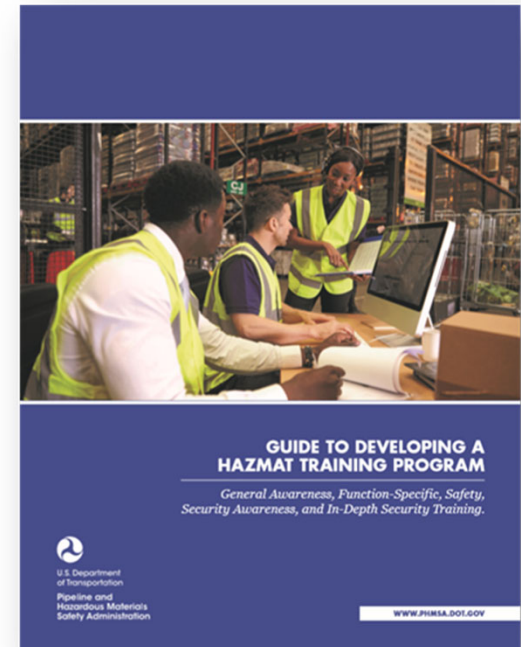

# Training Sources

- Training may be provided by the employer or other public or private sources
- USDOT does not *approve, endorse, or certify* anyone's training program or product.
- Hazmat training received from a previous employer or other source can be used to meet the HMR requirements provided that a current record of training is obtained from the previous employer





- Online, self-paced training
- Free of charge
- Requires unique log-in for trainees
- Helpful recordkeeping
- Satisfies General Awareness/Familiarization and Security Training Requirements

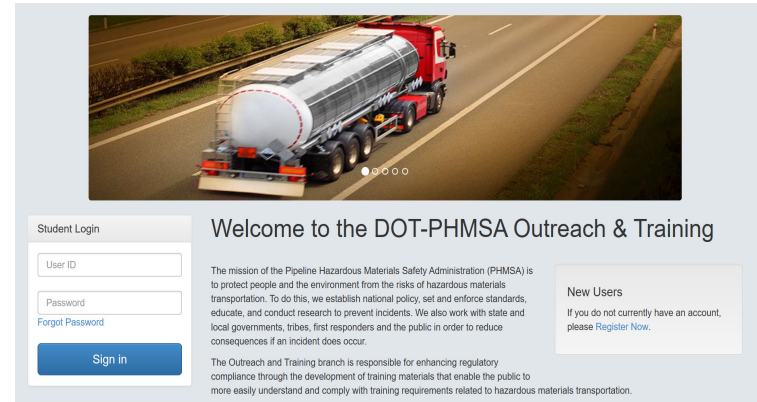

# PHMSA Training Modules (2 of 2)



Air - §175.20



Highway -  
§177.800 &  
§177.816



Vessel - §176.13



# Quick Knowledge Review

1. Developing a safety culture
2. Hazmat employers and hazmat employee definitions and responsibilities
3. Required parts of training
4. Testing of hazmat employees
5. Recordkeeping and record retention
6. Training sources
7. Awareness of modal specific training



# 49 CFR Part 172 Subpart I

## Safety and Security Plans





# Security Requirements (1 of 2)

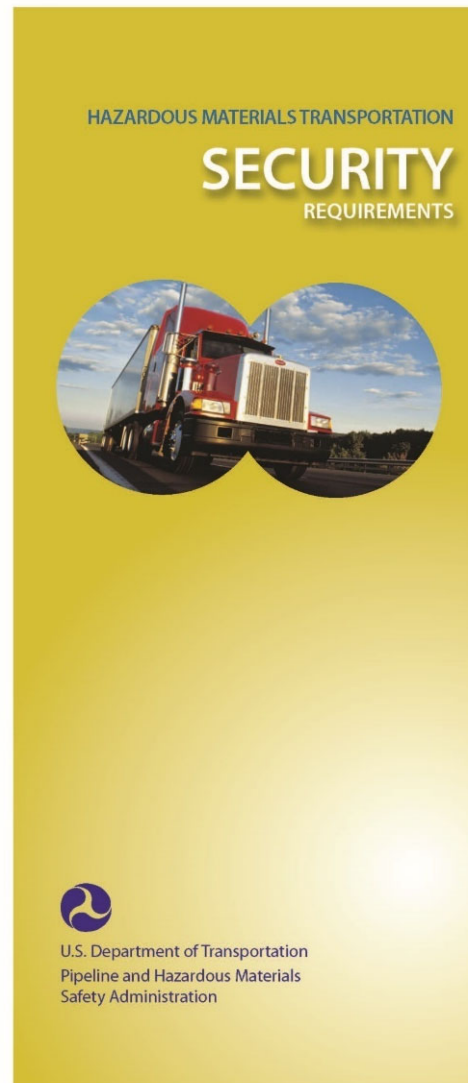

## LEARNING AID: 49 CFR, Subpart I



# Security Requirements (2 of 2)

- Identify materials subject to having a plan
- Assess the threat
- Write and record security plan
- Training employees on the plan

**LEARNING AID: 49 CFR, Subpart I**



# Determining If You Are Subject

## Definition of Large Bulk Quantity:

- 3,000 kg (6,614 pounds) for solids
- 3,000 liters (792 gallons) for liquids
- Gases in a single packaging such as a cargo tank motor vehicle, portable tank, tank car, or other bulk container



**LEARNING AID: 49 CFR, Part 172, Subpart I, Section 172.800 (b)**

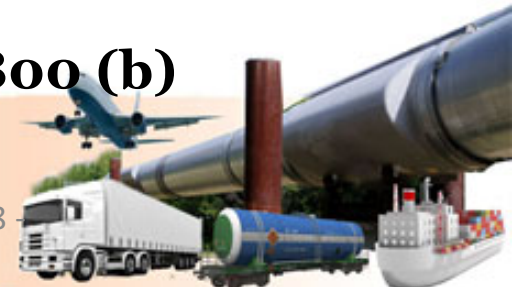

# Quick Knowledge Review

1. Developing a safety culture
2. Roles and Responsibilities
3. Required Parts of training
4. Testing, recordkeeping and retention best practices
5. Training sources
6. What necessitates a security plan



# Course Evaluation

## TELL US HOW WE DID!

Scan the QR code or go to the below link and tell us how we can improve!



<https://www.surveymonkey.com/r/5DBGHFW>





# Resource Share

For additional information contact:

## The Hazardous Materials Info Center

**1-800-HMR-4922**

(1-800-467-4922)

E-mail: [infocntr@dot.gov](mailto:infocntr@dot.gov)

<https://www.phmsa.dot.gov>

### Pipeline and Hazardous Materials Safety Administration Outreach, Engagement and Grants Division

East building, 2<sup>nd</sup> Floor  
1200 New Jersey Ave., SE

Washington DC 20590

E-mail: [training@dot.gov](mailto:training@dot.gov)

202.366.4900

202.366.7342 (Fax)



# HAZMAT Safety Assistance Team

## Jack Whitley (Western Region)

- [Earl.Whitley@dot.gov](mailto:Earl.Whitley@dot.gov)
- AK, AZ, CA, CO, HI, ID, MT, NV, OR, UT, WA, WY, Guam

## Dan Richards (Central Region)

- [Daniel.Richards@dot.gov](mailto:Daniel.Richards@dot.gov)
- IN, IL, MI, MN, WI, IA, NE, KS, MO, ND, SD

## Liz LaDow (Southern Region)

- [Elizabeth.Ladow@dot.gov](mailto:Elizabeth.Ladow@dot.gov)
- NC, SC, GA, FL, AL, MS, TN, KY, PR, USVI

## Shawn Daniels (Southwest Region)

- [Shawn.Daniels@dot.gov](mailto:Shawn.Daniels@dot.gov)
- LA, AR, OK, TX, NM

## Ijeoma George (Eastern Region)

- [Ijeoma.George@dot.gov](mailto:Ijeoma.George@dot.gov)
- CT, DE, D, NC, ME, MD, MA, NH, NJ, NY, PA, RI, VT, VA, WV

## Wayne Lalicon (Eastern Region)

- [Wayne.Lalicon@dot.gov](mailto:Wayne.Lalicon@dot.gov)
- CT, DE, D, NC, ME, MD, MA, NH, NJ, NY, PA, RI, VT, VA, WV





# QUESTIONS?



# Upcoming OneLab Network Events



## The Survey Process: What you need to know for your CLIA Survey

**MARCH 28, 2023**

Marranda Scott, a Clinical Laboratory Scientist with the Division of Laboratory Systems, will share her experience as a former CMS surveyor, including stories, resources, and insight on how surveyors approach and experience inspections and what laboratories can do to prepare for inspections successfully. All laboratory staff are encouraged to participate in this call.

***Register Now!***

[https://cdc.zoomgov.com/webinar/register/WN\\_3Dm3Gk6rS9eHOXpLfz1w](https://cdc.zoomgov.com/webinar/register/WN_3Dm3Gk6rS9eHOXpLfz1w)